

EFFECTIVE:
25-OCT-19

DIMENSION PRINT

TEFC - WITH STEARNS BRAKE

PRINT:
07-3292

SUPERSEDES:
24-AUG-16

FRAME: 140TC
BASIC TYPE: UTF

SHEET:
1 OF 1

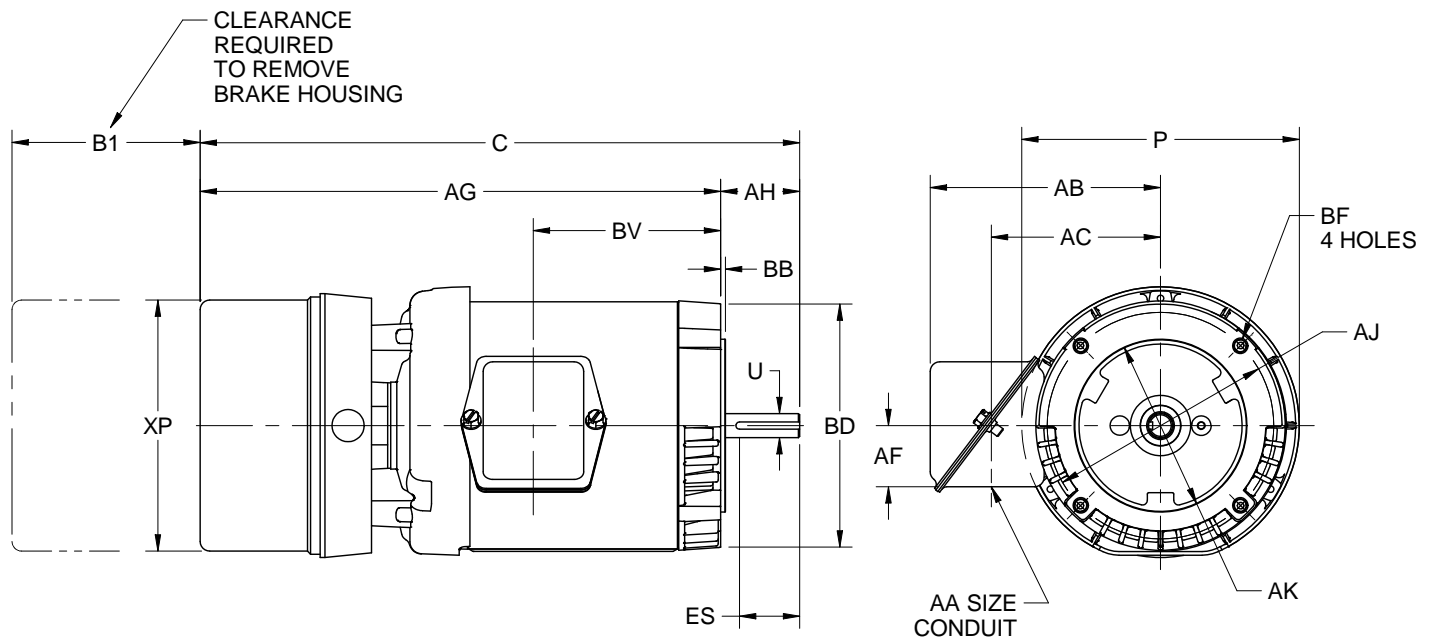

ALL DIMENSIONS ARE IN INCHES AND MILLIMETERS

UNITS	C	P ²	U -.0005	AA	AB	AC	AF	AG	AH	AJ	AK -.003
IN	17.94	7.25	.8750	.75	6.00	4.41	1.59	15.81	2.13	5.875	4.500
MM	456	184	22.225		152	112	40	402	54	149.23	114.30

UNITS	BB	BD MAX	BF ³	BV	B1	ES MIN	XP	SQ KEY
IN	.16	6.50	3/8-16 X .75	7.13	2.94	1.53	6.54	.188
MM	4	165		181	75	39	166	4.78

NOTE:
THIS PRINT IS GOOD FOR MOTORS WITH STEARNS BRAKE 56,3XX SERIES, (NEMA 1) ENCLOSURE RANGING FROM 1.5 THRU 15 LB. FT.

1. DIMENSIONS MAY VARY .25" DUE TO CASTING AND/OR FABRICATION VARIATIONS.
2. LARGEST MOTOR WIDTH.
3. TAP SIZE AND BOLT PENETRATION ALLOWENCE.
4. ALL TAPPED HOLES ARE UNIFIED NATIONAL COARSE, RIGHT HAND THREAD.
5. CONDUIT BOX MAY BE LOCATED ON EITHER SIDE OF MOTOR. CONDUIT OPENING MAY BE LOCATED IN STEPS OF 180° REGARDLESS OF LOCATION. STANDARD AS SHOWN WITH CONDUIT OPENING DOWN.
6. TOLERANCES ARE IN INCHES.
7. FRAME REFERENCE: 7.750/143/145

TOLERANCES	
FACE RUNOUT	.004 T.I.R.
PERMISSIBLE ECCENTRICITY OF MOUNTING RABBET	.004 T.I.R.
PERMISSIBLE SHAFT RUNOUT	.002 T.I.R.

07-3292/A

Nidec Motor Corporation
St. Louis, Missouri

INFORMATION DISCLOSED ON THIS DOCUMENT IS CONSIDERED PROPRIETARY AND SHALL NOT BE REPRODUCED OR DISCLOSED WITHOUT WRITTEN CONSENT OF NIDEC MOTOR CORPORATION



ISSUED BY K. FRIEDMAN
APPROVED BY C. COUCH

IHP_DP_NMCA (MAR-2011) SOLIDEDGE